

一体式控制系统
默认CL系统, 可选配维宏或新代

Z轴使用TBI丝杆驱动, 标准套件
(某些厂家省去电机座, 大幅降低精度)

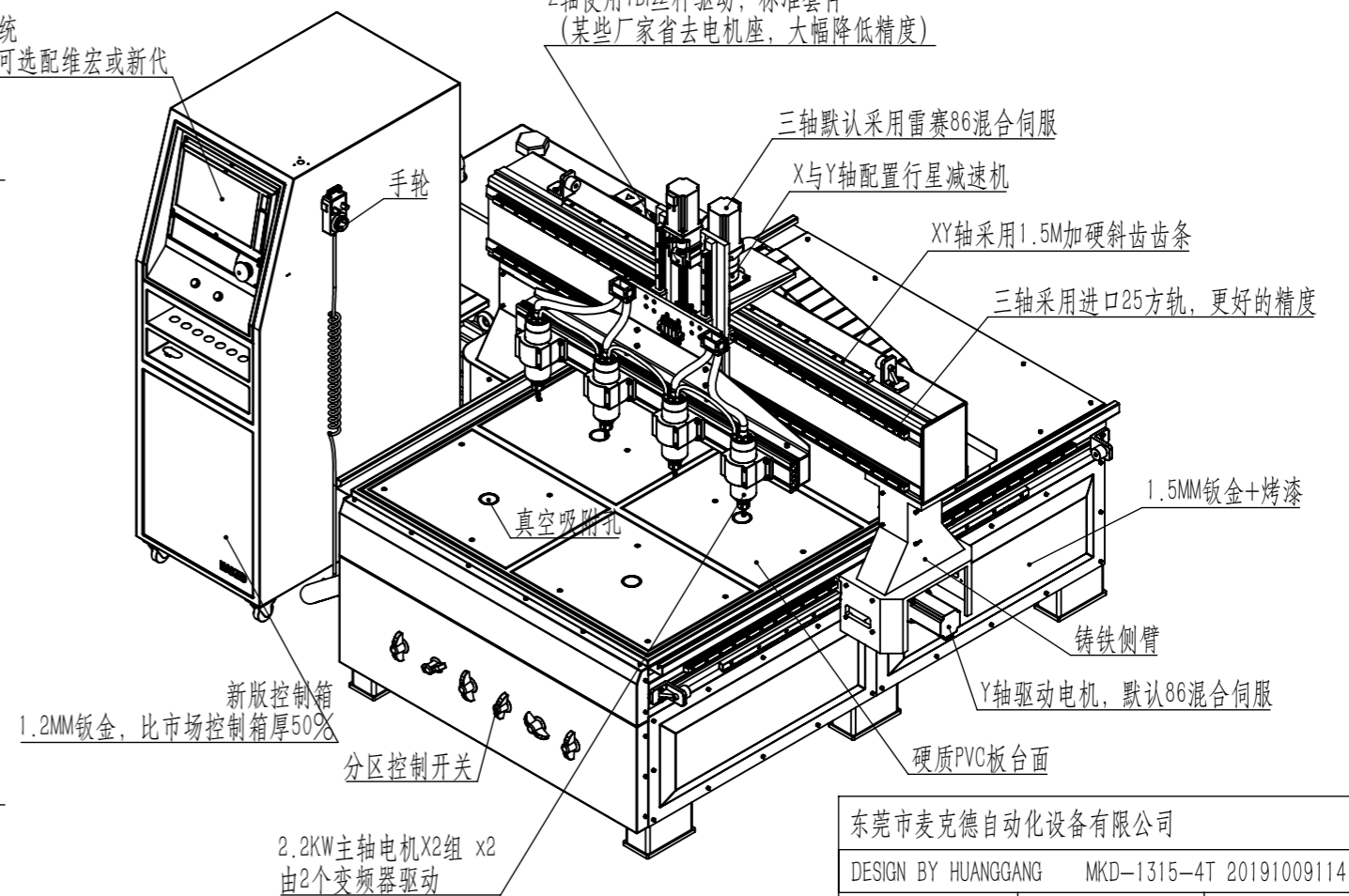

东莞市麦克德自动化设备有限公司

DESIGN BY HUANGGANG MKD-1315-4T 201910091141

0769-8187 8981 | 137 9021 2549 | www.mkdnc.com